

**DOCUMENT FEEDER  
DF UNIT TYPE 50 (50-SHEET)  
(C562)**

## 1. OVERALL MACHINE INFORMATION

### 1.1 SPECIFICATIONS

Original Type:	Sheet-feed
Original Paper Size:	Maximum 307 mm x 432 mm (12.0" x 17.0") Minimum 90 mm x 140 mm (3.6" x 5.5")
Original Weight:	40.7 g/m <sup>2</sup> to 127.9 g/m <sup>2</sup> , 10.8 lb to 34 lb
ADF Original Capacity:	50 sheets (66 g/m <sup>2</sup> , 17.6 lb) 42 sheets (80 g/m <sup>2</sup> , 20 lb) or 4.2 mm, 0.15" height

### 1.2 MECHANICAL COMPONENT LAYOUT

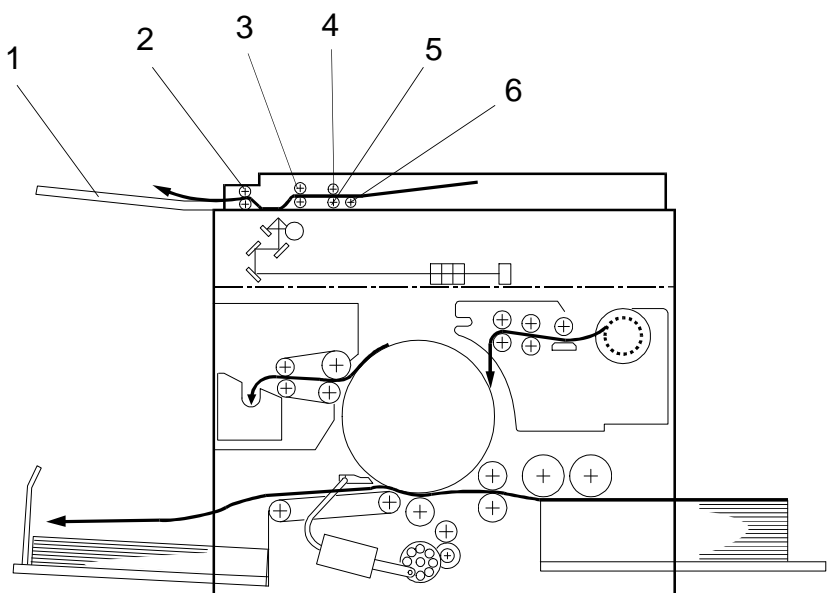

C562V500.wmf

1. Original Exit Tray
2. 2nd Original Transport Roller
3. 1st Original Transport Roller
4. Separation Roller
5. Feed Roller
6. Pickup Roller

DF  
(C562)

### 1.3 ELECTRICAL COMPONENT LAYOUT

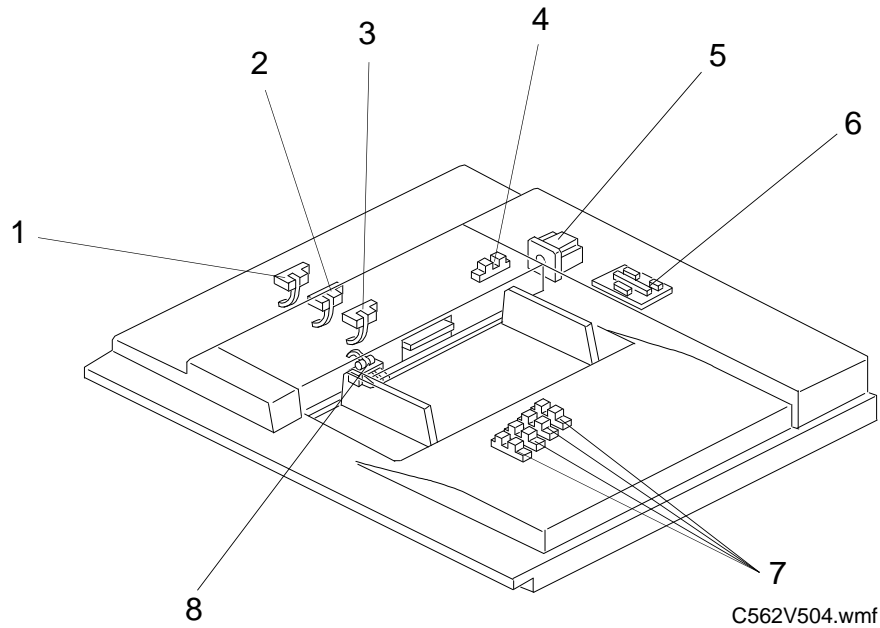

- |                                 |                          |
|---------------------------------|--------------------------|
| 1. Original Exit Sensor         | 5. ADF Motor             |
| 2. Scan Line Sensor             | 6. ADF Interface Board   |
| 3. Original Registration Sensor | 7. Original Width Sensor |
| 4. ADF Cover Sensor             | 8. Original Set Sensor   |

### COMPONENT DESCRIPTION

Index No.	Name	Function
1	Original Exit Sensor	Informs the CPU when the original activates the sensor. Also detects original misfeeds.
2	Scan Line Sensor	Determines the timing for scanning. Also detects original misfeeds.
3	Original Registration Sensor	Determines the timing for the ADF motor to start. Also detects original misfeeds.
4	ADF Cover Sensor	Informs the CPU when the ADF cover is opened.
5	ADF Motor	Drives the mechanisms in the ADF.
6	ADF Interface Board	Controls the ADF in response to signals from the main body.
7	Original Width Sensor	Informs the CPU of the original width.
8	Original Set Sensor	Informs the CPU when an original is placed in the ADF.

## 2. SECTIONAL DESCRIPTIONS

### 2.1 DRIVE MECHANISM

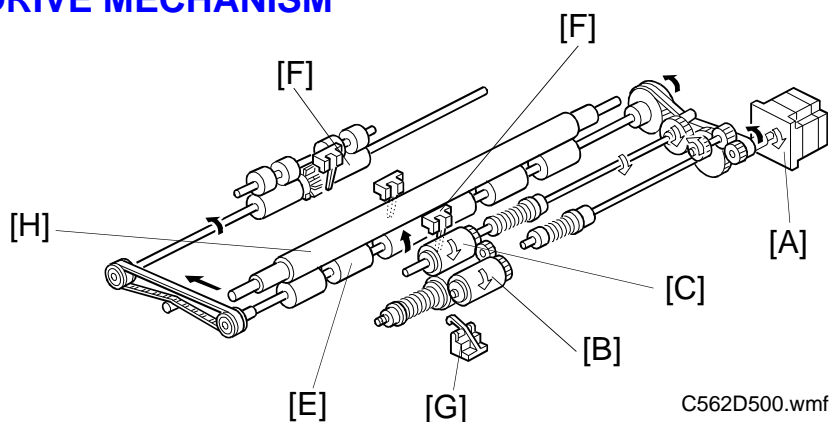

- [G]: Original Set Sensor
- [H]: 1st Original Transport Roller

The ADF motor [A] is a stepper motor. The ADF motor rotates clockwise and then counterclockwise to feed the original. When the Master Making key is pressed, the ADF motor rotates clockwise to drive the pick up roller [B] and the feed roller [C] turns clockwise to feed the top page of the original. When the original has been fed 14.5 mm after the original registration sensor [D] was activated, the ADF motor starts to rotate counterclockwise. This drives the lower 1st original transport roller [E] and the lower original exit roller [F] counterclockwise, feeding the original.

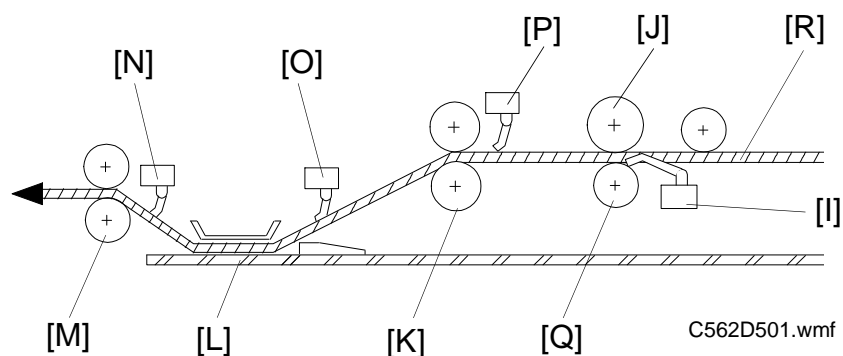

- |                                    |                                   |
|------------------------------------|-----------------------------------|
| [I]: Original Set Sensor           | [N]: Original Exit Sensor         |
| [J]: Feed Roller                   | [O]: Scan Line Sensor             |
| [K]: 1st Original Transport Roller | [P]: Original Registration Sensor |
| [L]: Exposure Glass                | [Q]: Separation Roller            |
| [M]: 2nd Original Transport Roller | [R]: Original Paper Path          |

DF  
(C562)

## 2.2 PAPER FEED AND SEPARATION

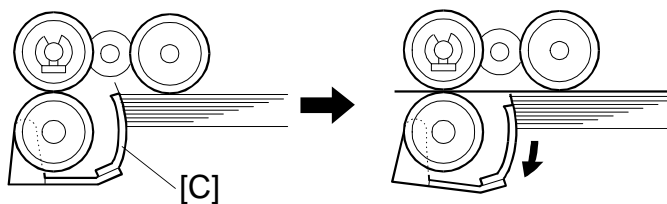
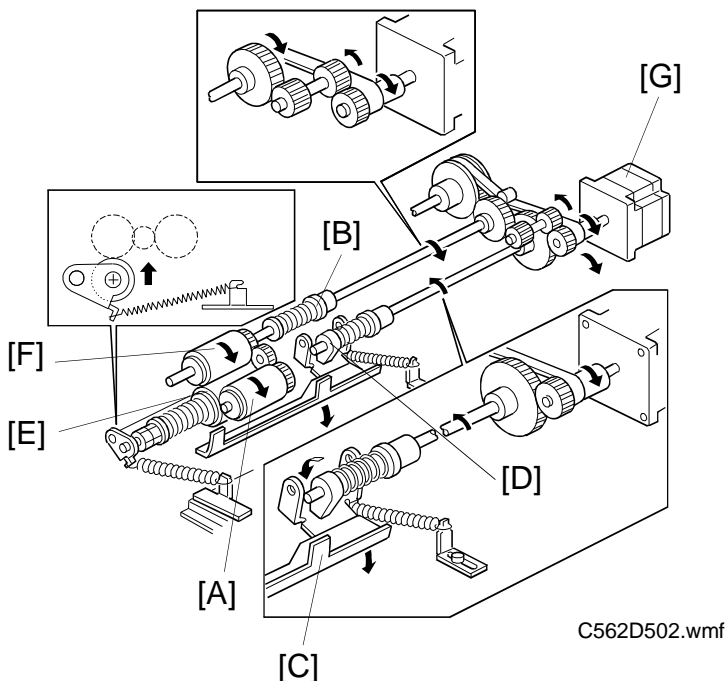

When the originals are placed on the ADF and the Master Making key is pressed, the pickup roller [A] starts to rotate as it is lowered by the spring clutch [B] to touch the top page of the document. The original shutter [C] is lowered by the spring clutch and the lever [D] when the ADF motor is turned on. The separation roller [E] and the feed roller [F] allow only one page into the scanner. The one-way clutch on the feed roller prevents its backward rotation when the ADF motor [G] rotates counterclockwise.

The pick-up and the shutter torque are adjustable by the length of the spring. See Pick-up Torque Adjustment and Shutter Torque Adjustment for details.

## 2.3 ORIGINAL SIZE DETECTION

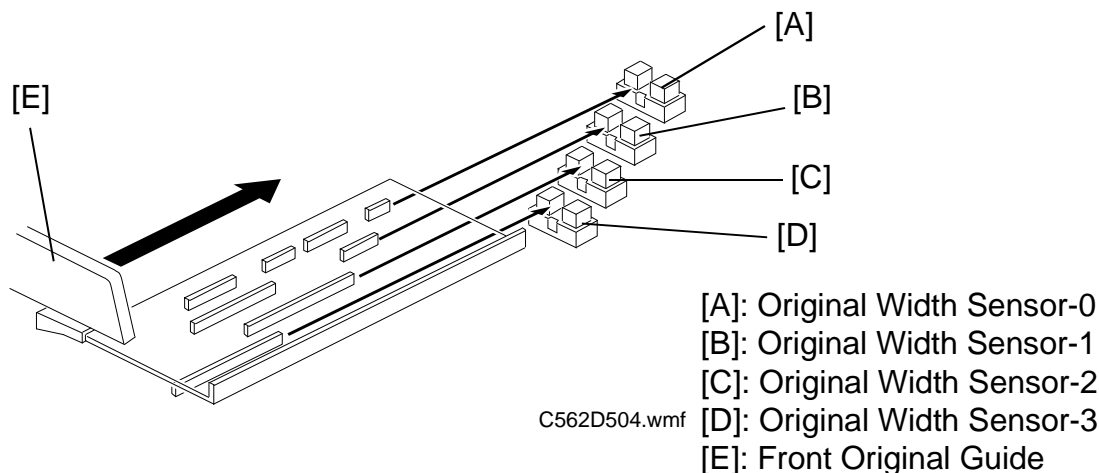

There are 4 sensors (photointerrupters) for detecting the original width. When the front original guide [E] is shifted to match the original width, the plate [F] moves with the guide. Eight actuators are installed on the plate, and depending on the side guide position, the sensor status will be changed. The following table shows the relationship between the paper size and the sensor status.

Original Size	A3	DLT	B4	LT/LG	A4	B5	A5
Original Size Sensor-0	O		O			O	
Original Size Sensor-1		O	O			O	O
Original Size Sensor-2			O	O	O	O	
Original Size Sensor-3					O	O	O

X= Non-blocked, O= Blocked

\* : All of the above original sizes are for lengthwise feed.

## 2.4 ORIGINAL MISFEED DETECTION

The machine indicates an original misfeed in the following conditions.

- When the original registration sensor does not go ON within 3 seconds after the ADF motor starts rotating (clockwise).
- When the scan line sensor does not go ON within 2.5 seconds after the original registration sensor is turned on.
- When the original exit sensor does not go ON after the scan line sensor is turned on and the original has been fed 60 millimeters.



## 2.5 ADF OPEN/CLOSE DETECTION

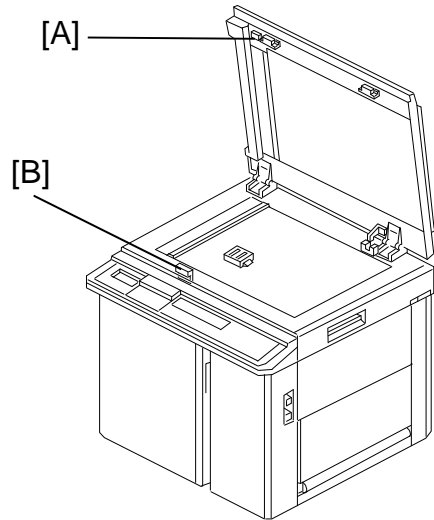

C562D505.wmf

The ADF set sensor detects whether the ADF unit is opened or closed. This sensor is a reed switch. A magnet mounted on the ADF [A] activates the reed switch [B]. When an original is placed in the ADF, if this reed switch is not activated, the Master Making key is disabled.

## 2.6 ADF POSITION DETECTION

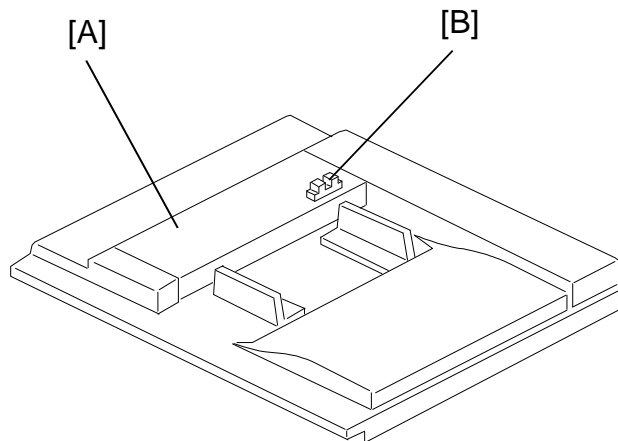

C562D506.wmf

When the ADF cover [A] is opened, the platen cover position sensor [B] is deactivated. When this sensor is deactivated, the Master Making key is disabled.

## 3. INSTALLATION PROCEDURE

### 3.1 ACCESSORY CHECK

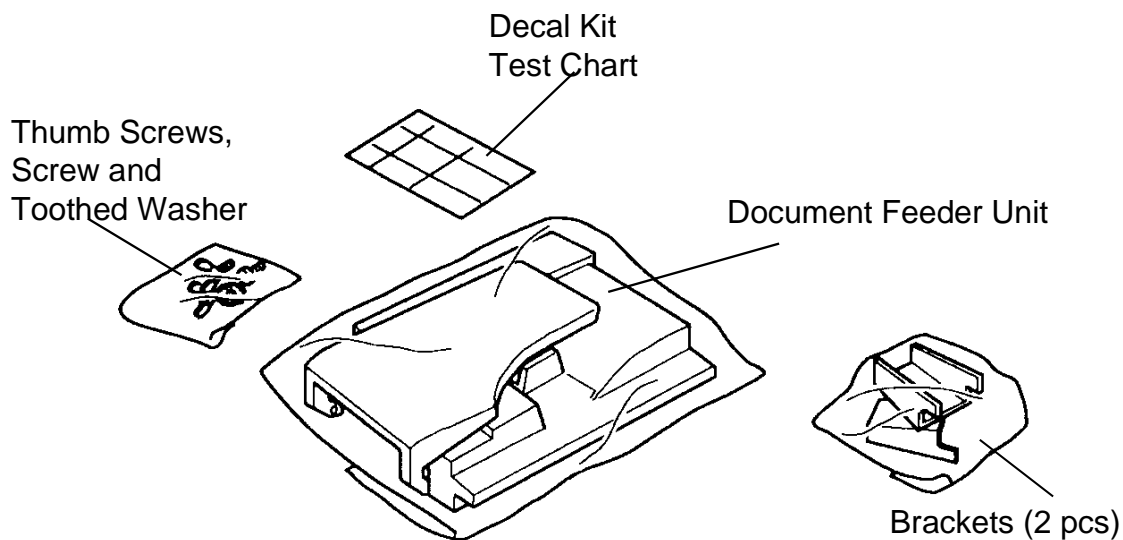

C562I500.img

Make sure that you have all the accessories listed below.

- (1) Document Feeder Unit
- (2) Bracket (2 pcs.)
- (3) Screw and a Toothed Washer
- (4) Thumb Screws (4 pcs.)
- (5) Test Chart
- (6) Installation Procedure
- (7) Decal Kit



### 3.2 INSTALLATION PROCEDURE

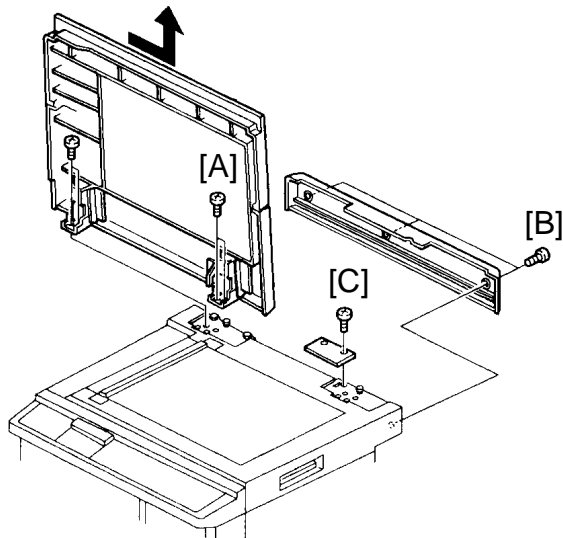

C562I501.img

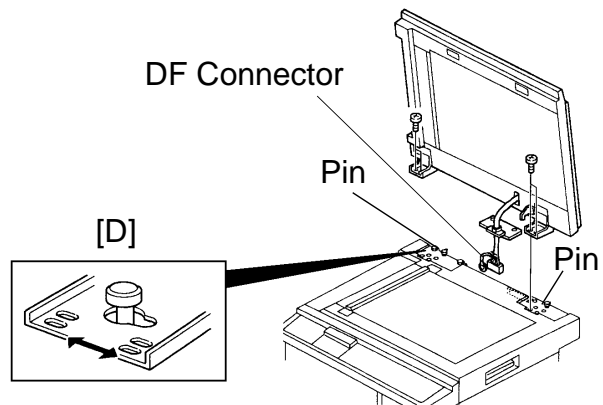

C562I502.img

1. Turn off the main switch and unplug the power cord.
2. Open the Platen Cover, remove 4 screws [A] and remove the Platen Cover.
3. Remove 3 screws [B] and remove the Upper Rear Cover.
4. Remove 2 screws [C] and remove the cover plate.
5. Let the DF connector through the opening and mount the DF Unit as shown in the diagram [D].
6. Secure the DF Unit by 4 screws that were removed in step 2.

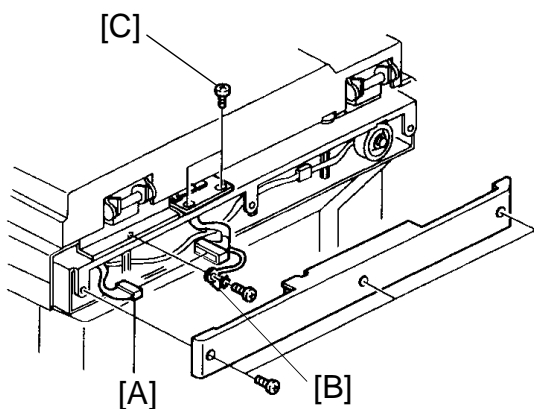

C562I503.img

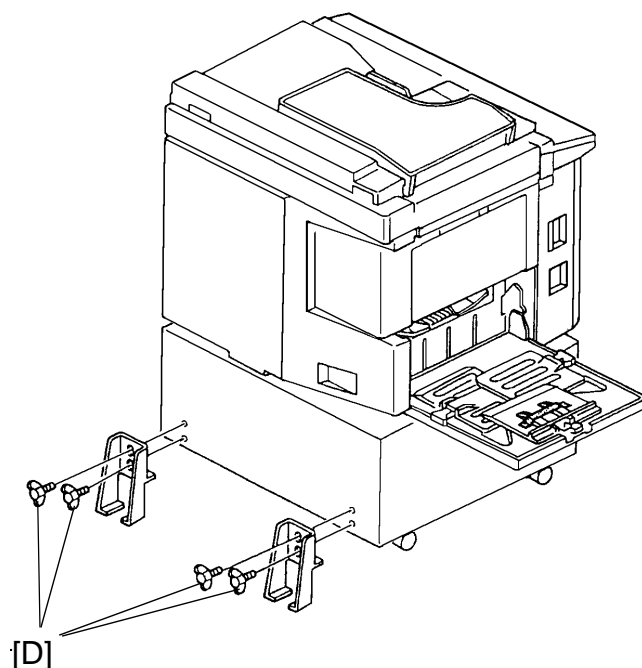

C562I504.img

7. Close the DF and connect the connector to the scanner connector [A].
8. Secure the wire [B] by the screw and the washer in the accessory.
9. Secure the DF Harness Bracket by 2 screws [C].
10. Replace the Upper Rear Cover by 3 screws.
11. Secure the machine by placing 2 brackets [D] on the back of the table using 4 thumb screws in the accessory.

**⚠ CAUTION**

**The brackets must be attached to the back of the table. This is to prevent the machine from falling over when the ADF is opened. Also, make sure that the machine is secured to the table.**

**DF  
(C562)**

When C562 is installed on the C222 or C223 model, change the SP mode setting as follows: (The following procedure is not required for C550.)

**For the C222 model:**

12. Press the Clear Modes, Clear, Combine 2 Originals and Enter (#) keys to access the SP mode.
13. Change the setting of SP2-50 from OFF to ON. Then press the Enter Key to store the setting.
14. Leave the SP mode.

**For the C223 model:**

12. Press the Clear modes, Clear, Multi Copy and Enter(#) keys to access SP mode.
13. Change the setting of SP8 from 0 to 1.  
Then press the Enter key to store the setting.
14. Leave the SP mode.

When you install the optional ADF, do the following adjustments.

- ADF height adjustment.
- Image center adjustment.
- Image scan magnification adjustment.

## 4. SERVICE TABLES

### 4.1 USER'S MAINTENANCE

Advise the customer to clean each item regularly. Clean the following items at every EM call if necessary.

Cleaning Point	Cleaner
Original Feed Rollers	Cloth, soap, and water

### 4.2 PERIODIC INSPECTION

Inspect the following every 6 months.

Item	Standard Procedure
Pick-up Roller Feed Roller Separation Roller	Wipe off paper powder using a cloth moistened with water.

## 5. REPLACEMENT AND ADJUSTMENT

### 5.1 ADF UNIT REMOVAL

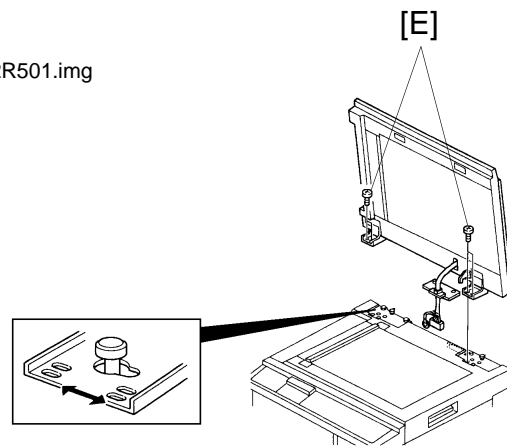
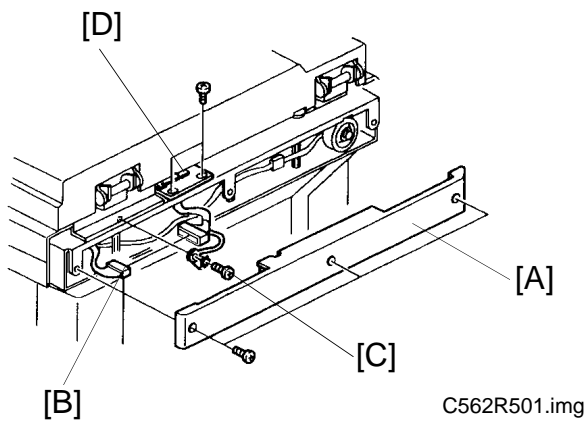

1. Remove the upper rear cover [A] of the main frame (3 screws).
2. Disconnect the connector [B], and remove the screw [C] that holds the ground wire.
3. Remove the DF harness bracket [D] (2 screws).
4. Open the ADF unit and remove the four screws [E] that hold the ADF unit hinge.
5. Slide the unit to the right and remove the ADF unit from the machine.

**NOTE:** When you reinstall the ADF unit, perform the following adjustments:  
 ADF Height Adjustment  
 Image Center Adjustment  
 Image Scan Magnification Adjustment

## 5.2 ADF COVER REMOVAL

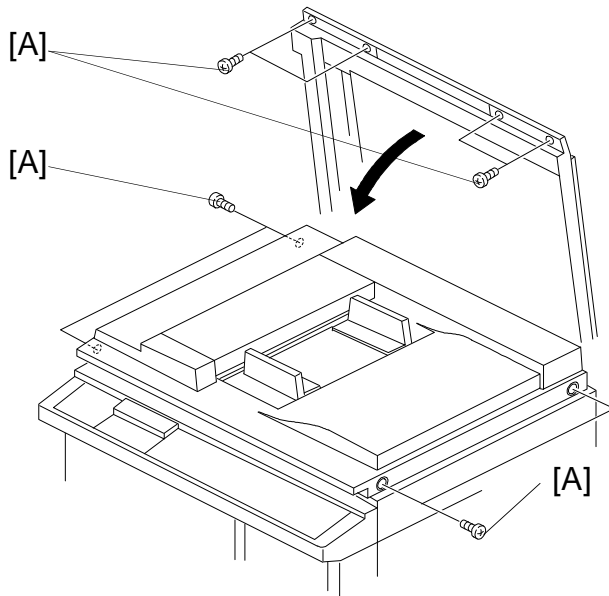

C562R502.wmf

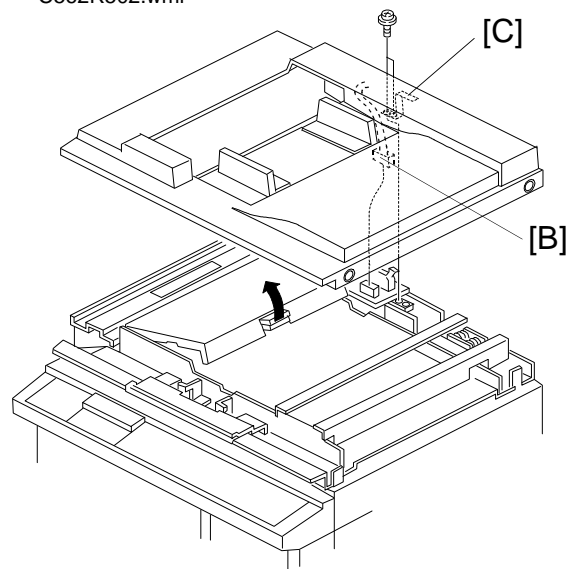

C562R503.wmf

1. Remove the screws [A] securing the ADF cover (8 screws).
2. Disconnect the original size detector harness [B].
3. Remove the harness protector [C] (2 screws).

DF  
(C562)

### 5.3 ADF UPPER UNIT REMOVAL

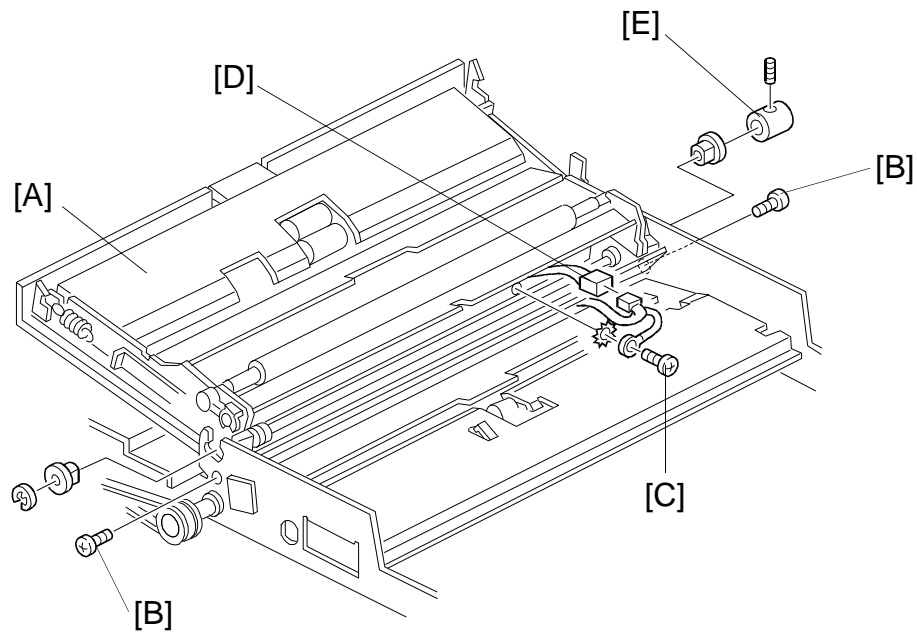

C562R527.wmf

1. Remove the ADF cover (see section 5-2).
2. Open the ADF unit [A] and remove two stopper screws [B].
3. Remove the ground wire [C] (1 screw, 1 toothed washer).
4. Disconnect the connector [D].
5. Remove the collar [E] (1 Allen screw).
6. Remove the ADF upper unit [A] (2 bushings, 1 E-ring).

## 5.4 SEPARATION ROLLER REMOVAL

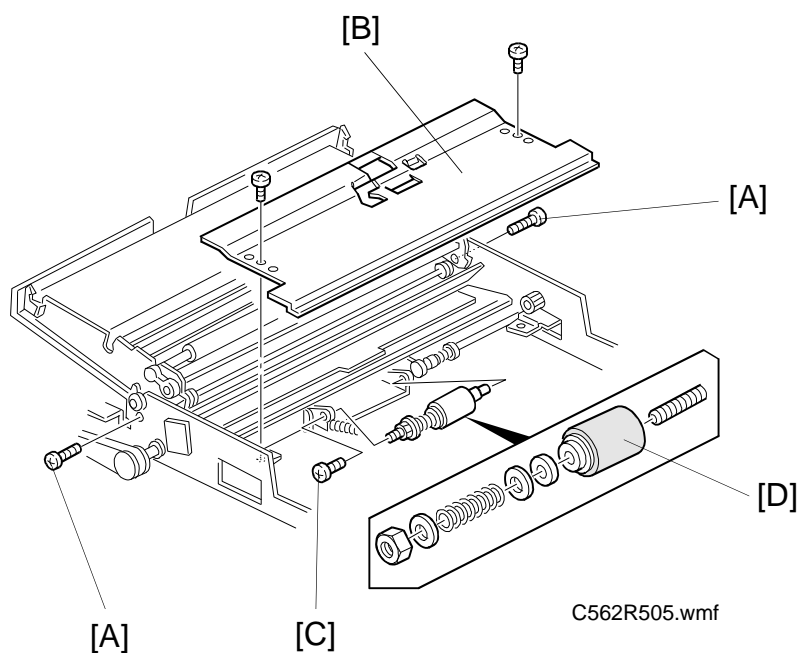

1. Remove the ADF cover (see section 5-2).
2. Remove the two stopper screws [A] and fully open the ADF upper unit.
3. Remove the lower guide plate [B] (2 screws).
4. Remove the screw [C] that holds the separation roller [D], and remove the separation roller.

**NOTE:** When replacing the separation roller, perform the separation torque adjustment (see section 5-15).



## 5.5 ORIGINAL SET SENSOR REMOVAL

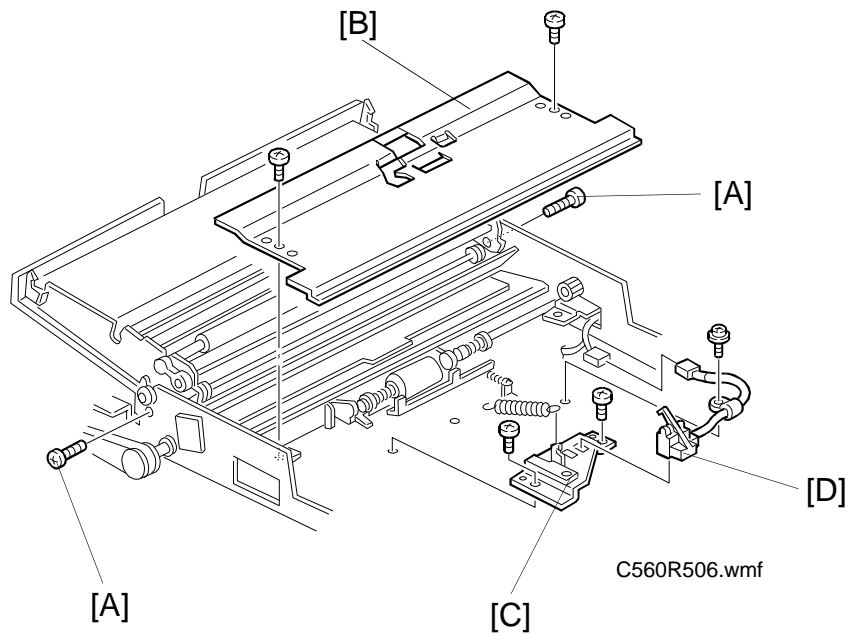

1. Remove the ADF cover (see section 5-2).
2. Remove the two stopper screws [A] and fully open the ADF upper unit.
3. Remove the lower guide plate [B] (2 screws).
4. Remove the sensor bracket [C] (2 screws) and remove the original set sensor [D].

## 5.6 ORIGINAL REGISTRATION SENSOR REMOVAL

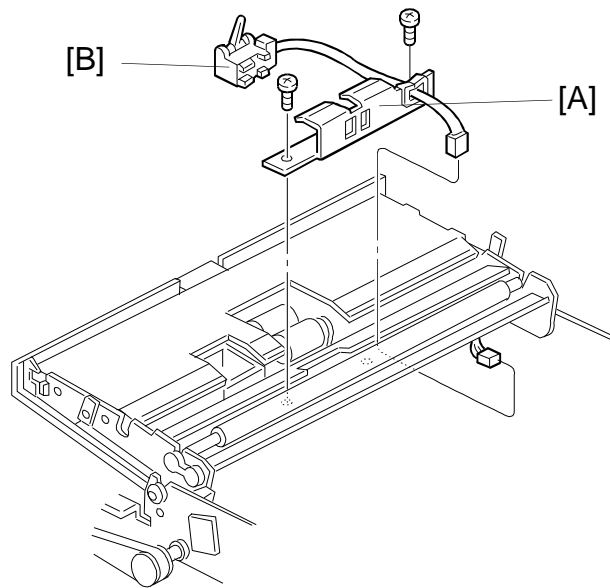

C562R507.wmf

1. Remove the ADF cover (see section 5-2).
2. Remove the two stopper screws and fully open the ADF upper unit (see the previous page).
3. Remove the sensor bracket [A] (2 screws) and remove the original registration sensor [B].

## 5.7 PICK-UP ROLLER AND FEED ROLLER REMOVAL

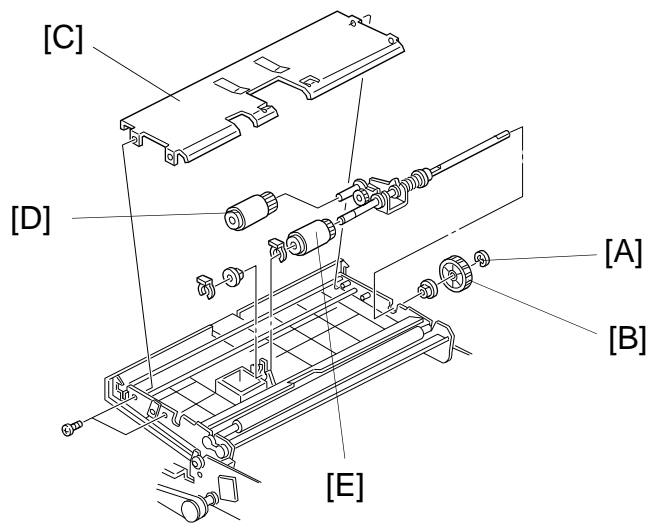

C562R522.wmf

1. Remove the ADF cover (see section 5-2).
2. Remove the two stopper screws and fully open the ADF upper unit (see section 5-5).
3. Remove the E-ring [A] and remove the pick-up roller drive gear [B].
4. Remove the upper guide plate [C].
5. Remove the pick-up roller [D].
6. Remove the clip and remove the feed roller [E].

## 5.8 SCAN LINE SENSOR REMOVAL

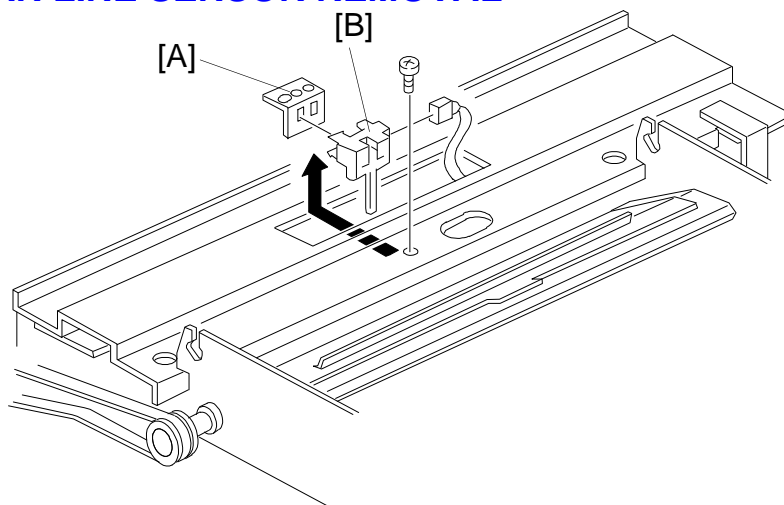

C560R508.wmf

1. Remove the ADF upper unit (see section 5-3).
2. Remove the sensor bracket [A] (1 screw).
3. Remove the scan line sensor [B] (1 connector).

## 5.9 ORIGINAL EXIT SENSOR REMOVAL

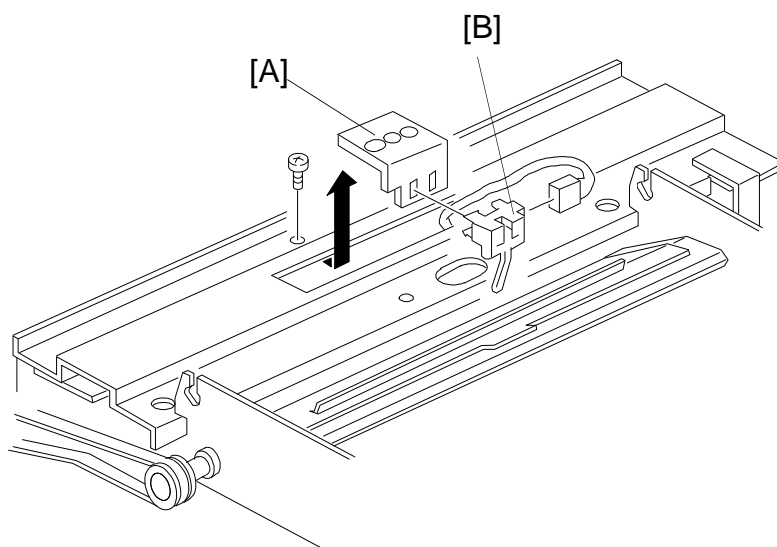

C562R609.wmf

1. Remove the ADF unit (see section 5-1).
2. Remove the sensor bracket [A] (1 screw).
3. Remove the original exit sensor [B] (1 connector).

DF  
(C562)

## 5.10 ADF COVER SENSOR REMOVAL

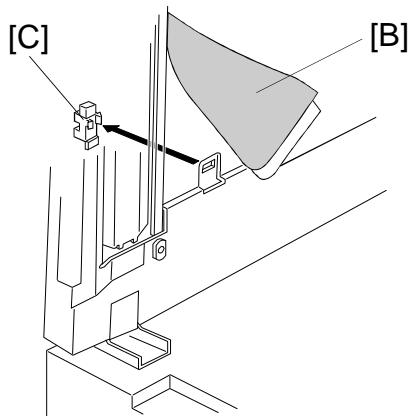

C562R523.wmf

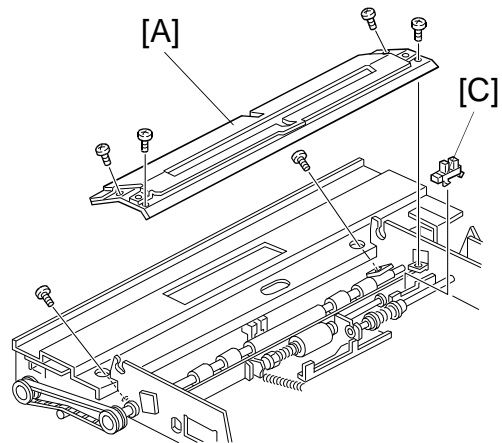

C562R524.wmf

1. Remove the ADF cover (see section 5-2).
2. Remove the ADF upper unit (see section 5-3).
3. Remove the lower guide plate (2 screws).
4. Remove the transport guide plate [A] (4 screws).
5. Open the ADF unit and peel away the platen sheet [B] to access the ADF cover sensor [C].
6. Remove the ADF cover sensor.

## 5.11 TRANSPORT ROLLER REMOVAL

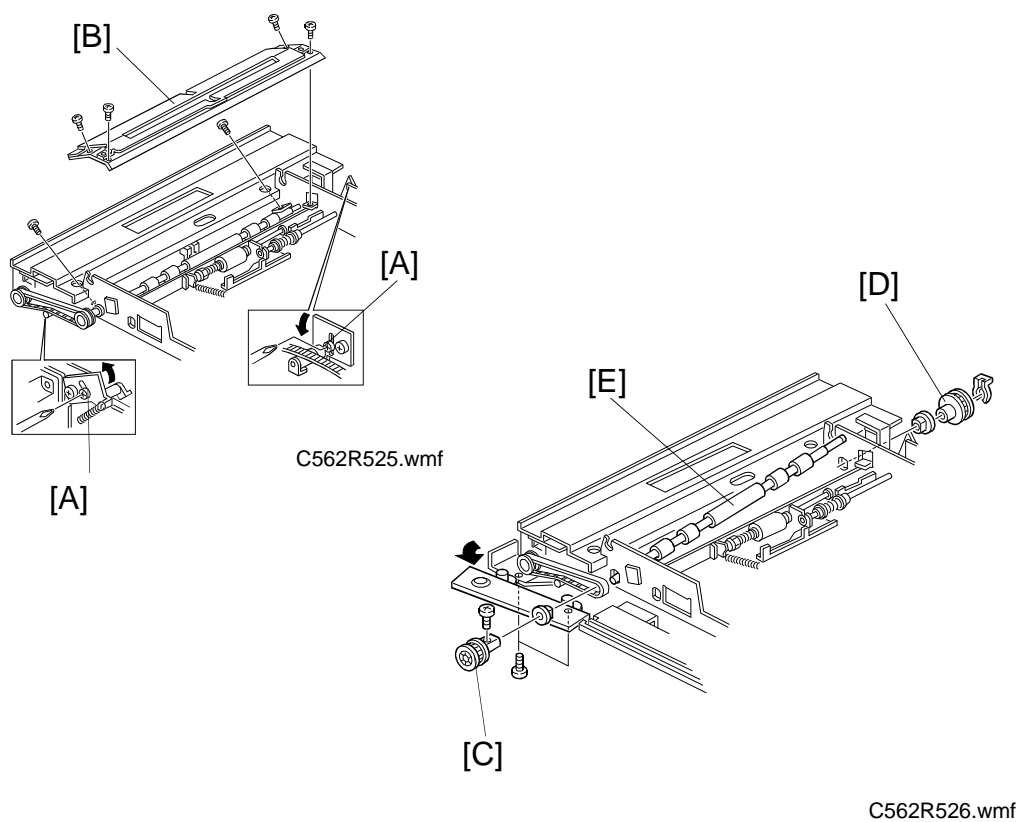

1. Remove the ADF cover (see section 5-2).
2. Remove the ADF upper unit (see section 5-3).
3. Loosen the screws [A] that hold the front and rear belt tension brackets.
4. Remove the transport guide plate [B] (4 screws).
5. Remove the front pulley [C] (1 screw).
6. Remove the rear pulley [D] (1 clip).
7. Remove the transport roller [E] (2 bushings).

**NOTE:** A one-way clutch is installed in the rear pulley [D]. Install the pulley in the proper direction.

DF  
(C562)

## 5.12 ADF MOTOR REMOVAL

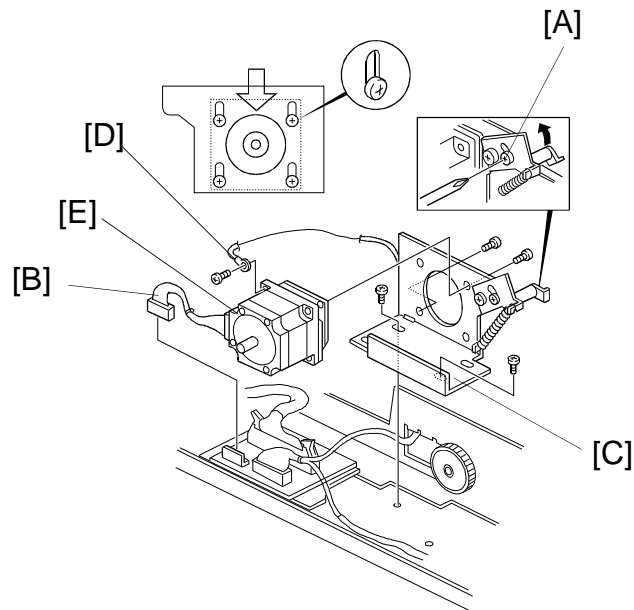

C562R514.wmf

1. Remove the ADF cover (see section 5-2).
2. Loosen the screw [A] securing the belt tension bracket.
3. Disconnect the motor harness [B].
4. Remove the motor bracket [C] (2 screws, 1 timing belt).
5. Remove the ground wire [D] (1 screw).
6. Remove the ADF motor [E] (2 screws).

**NOTE:** 1. When reinstalling the motor bracket, push down the bracket as shown, then tighten the four screws.  
2. After reinstalling the timing belt, make sure that you tighten the screw [A].

## 5.13 PICK-UP TORQUE ADJUSTMENT

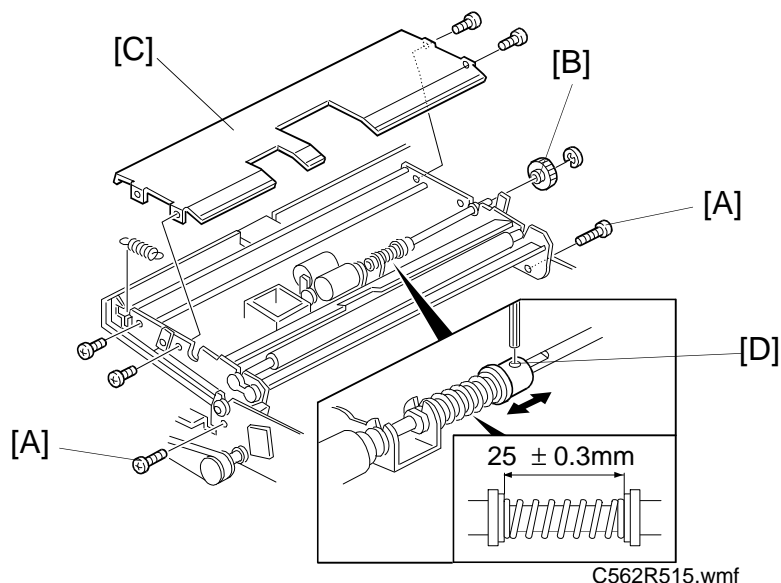

**Purpose:** To ensure that the originals are picked-up properly.

**Adjustment Standard:**  $25.0 \pm 0.3$  mm

1. Remove the ADF cover (see section 5-2).
2. Remove the two stopper screws [A] and fully open the ADF upper unit.
3. Remove the gear [B] (1 E-ring) and remove the upper guide plate [C] (4 screws).
4. Confirm that the length of the spring on the separation roller shaft is  $25.0 \pm 0.3$  mm.
5. If it is not within the specified range, loosen the Allen screw [D] and adjust the collar position.

**NOTE:** After this adjustment, check if the separation roller shaft rotates smoothly.



## 5.14 SHUTTER TORQUE ADJUSTMENT

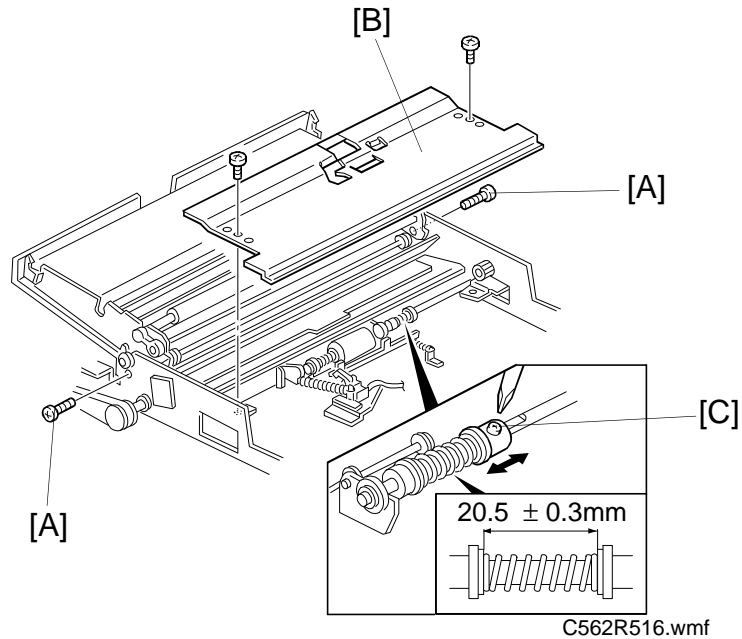

**Purpose:** To ensure that the original shutter functions properly.

**Adjustment Standard:**  $20.5 \pm 0.3$  mm

1. Remove the ADF cover (see section 5-2).
2. Remove the two stopper screws [A] and fully open the ADF upper unit.
3. Remove the lower guide plate [B] (2 screws).
4. Confirm that the spring length is  $20.5 \pm 0.3$  mm.
5. If the value is not within the specified range, loosen the screw [C] and adjust the spring length by sliding the collar.  
If the original is not transported after moving the stopper, extend the spring length.  
If original multi-feed occurs, shorten the spring length.

## 5.15 SEPARATION ROLLER TORQUE ADJUSTMENT

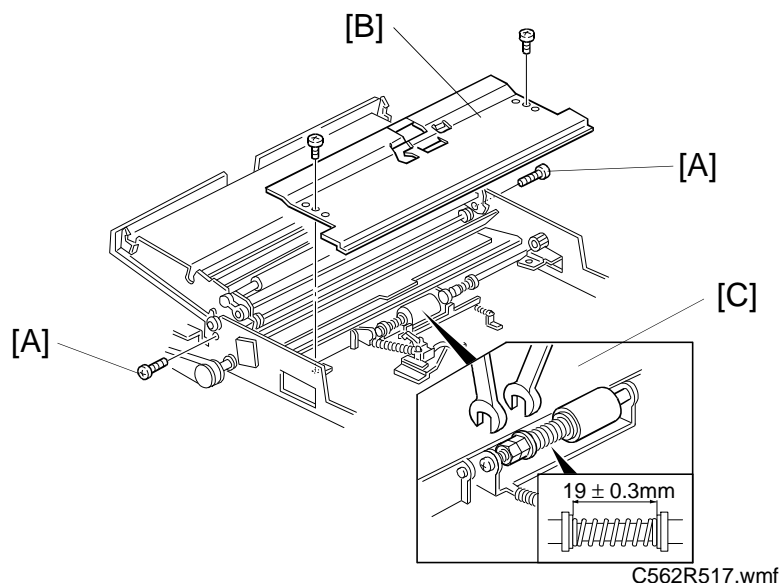

**Purpose:** To ensure that the top original is properly separated from the original stack.

**Adjustment Standard:**  $19.0 \pm 0.3\text{ mm}$

1. Remove the ADF cover (see section 5-2).
2. Remove the two stopper screws [A] and fully open the ADF upper unit.
3. Remove the lower guide plate [B] (2 screws).
4. Check the separation torque spring length.
5. If the length is not within the specified range, turn the hexagon bolts [C] to adjust the separation roller torque.

## 5.16 ORIGINAL SKEW ADJUSTMENT

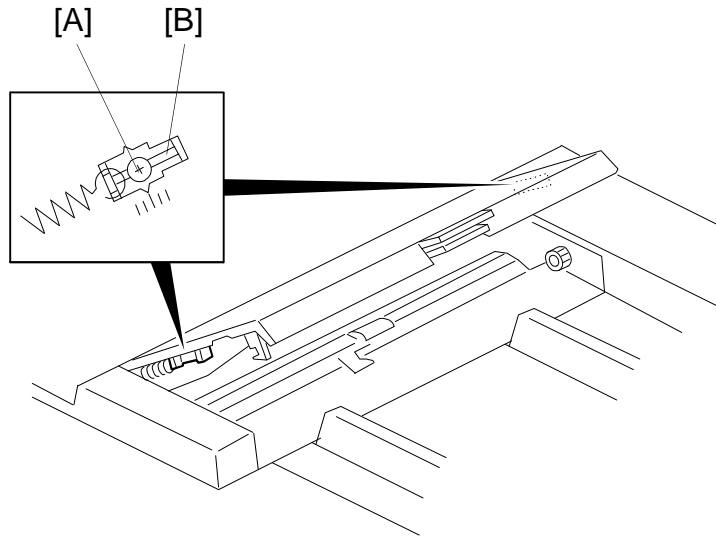

C562R518.wmf

**Purpose:** To correct original skew.

1. Open the ADF unit.
2. Loosen the screw [A] and move the adjustment plates to correct the skew.
3. After adjusting the skew, tighten the plate properly.

## 5.17 ORIGINAL SEPARATION PRESSURE ADJUSTMENT

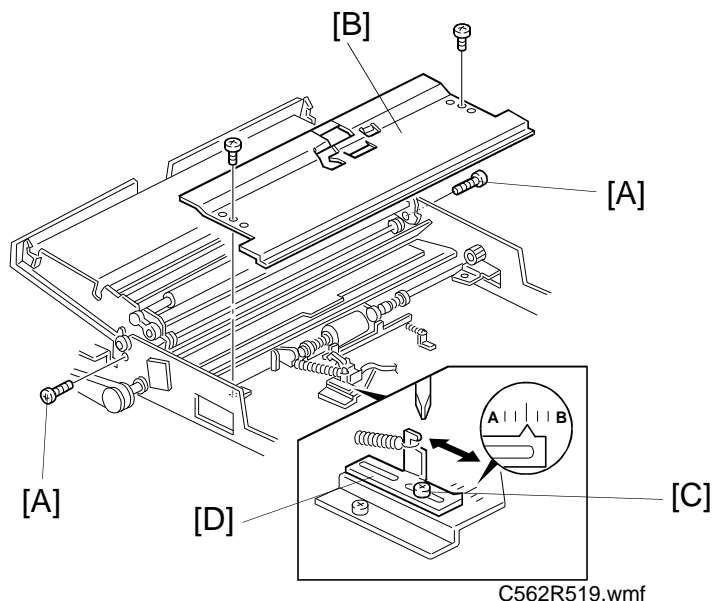

**Purpose:** To ensure that the top original is properly separated from the original stack.

1. Remove the ADF cover (see section 5-2).
2. Remove the two stopper screws [A] and fully open the ADF upper unit.
3. Remove the lower guide plate [B] (2 screws).
4. Loosen the screw [C] securing the pressure adjusting lever [D] then move the lever to change the pressure.  
 Original non-feed: Move the lever towards "A" (to decrease the pressure).  
 Original multi-feed: Move the lever towards "B" (to increase the pressure).  
 After adjusting the pressure, tighten the screw [C].

## 5.18 ADF HEIGHT ADJUSTMENT

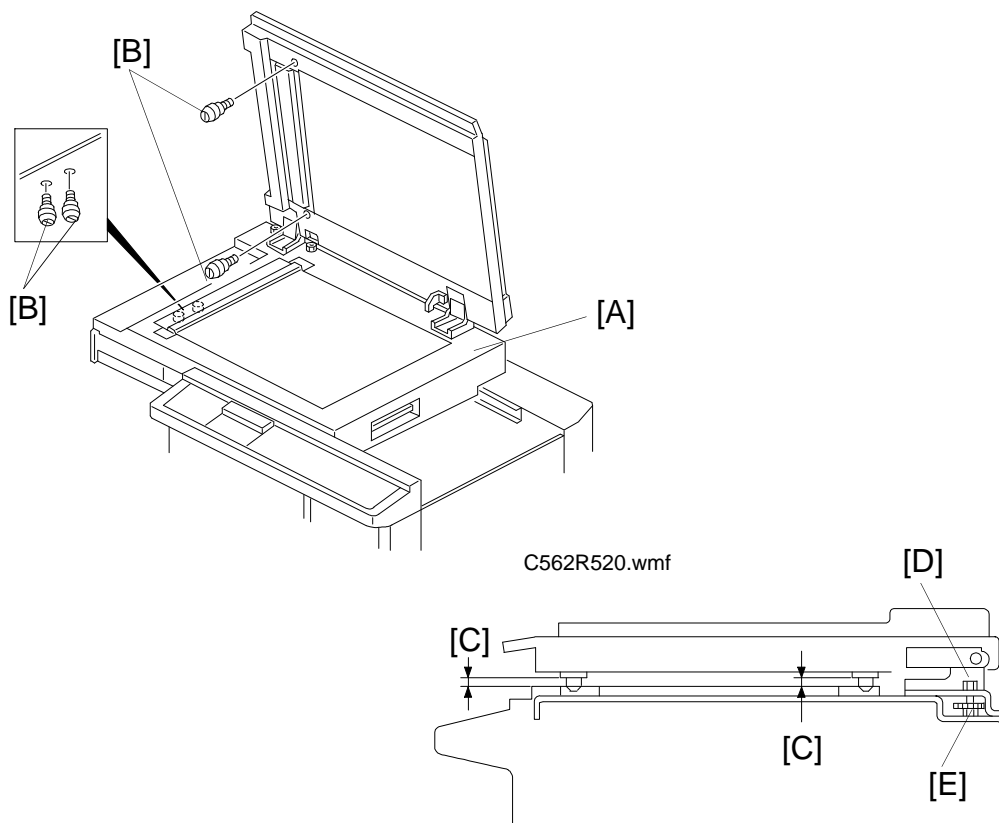

C562R520.wmf

C562R521.wmf

**Purpose:** To ensure that the image can be scanned properly.

**Adjustment Standard:** Less than 0.5 mm

1. Slide the scanner unit to the left [A].
2. Remove two positioning pins (white) [B] under the scanner unit. Then, attach them to the ADF as shown in the diagram.
3. Close the ADF and check that the gap [C] between the positioning pins and the scanner upper cover is less than 0.5 mm, using a thickness gauge.
4. If not, adjust the ADF height as follows.
  - 4-1. Remove the upper rear cover (see section 5-1 of the main frame's manual).
  - 4-2. Loosen the nut [D] and adjust the height by turning the knob screw [E]. Then, tighten the nut.
5. After adjusting the ADF height position, put the positioning pins back in their previous position (under the scanner unit).

## 5.19 IMAGE SCAN MAGNIFICATION ADJUSTMENT

**Purpose:** To correct the sub-scan magnification.

**Adjustment Standard:**  $100 \pm 0.5\%$  in full size mode.

1. Using a test chart, make a print in ADF mode.
2. Check if the sub-scan magnification is within the specified range.
3. If it is out of the specified range, adjust the sub-scan magnification using SP36.

## 5.20 IMAGE CENTER ADJUSTMENT (SIDE-TO-SIDE)

**Purpose:** To correct the center position of the printed image.

**Adjustment Standard:** Less than 1 mm

**NOTE:** Before adjusting the image center position in ADF mode, adjust the image center for platen mode.

1. Using a test chart, make a print using both ADF mode and platen mode.
2. Compare both copies and check that the difference between the two copies is within 1 mm.
3. If the difference is not within the specified range, adjust the image center using SP39-1.

## 5.21 SCANNER LEADING EDGE REGISTRATION ADJUSTMENT

**Purpose:** To adjust the vertical image position of the prints with that of the original.

**Adjustment Standard:** The scanning starts at 5 mm after the leading edge.

**NOTE:** When performing this adjustment, set the print speed and image position to the standard position.

1. Using a test chart, make a print in ADF mode.
2. Check the scanner start position and adjust the scanner leading edge registration using SP38.